

Load Break Switches

VITZROTECH Load Break Switches are available in medium voltage switching and protection to your distribution system with power fuses.

The switches are specially designed to handle all three phase live switching duties including full load and associated transformer magnetizing and cable charging currents including fault closing operations. They are fully type tested in KERI (Korea Electrotechnology Research Institute) under qualified system.

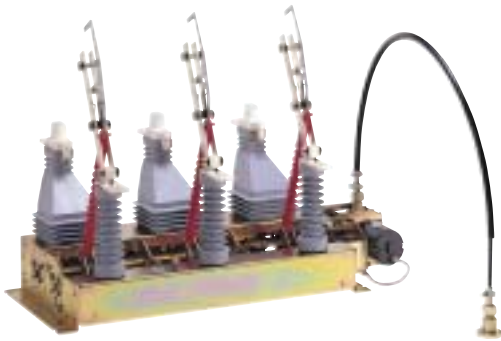

Rated voltage	12 / 15kV		24kV	
LBS type	12KML-M	12KMLF-M	KML-M	KML-A
Number of poles	3		3	
Rated current	630A		630A	
Rated frequency	AC50/60Hz		AC50/60Hz	
Power frequency withstand voltage	32kV		50kV	
Impulse withstand voltage(1.2x50 μsec)	85kV		125kV	
Short time withstand current, 1sec	20kA		20kA	
Short-circuit making current	52kA		52kA	
Load breaking current	630A		630A	
Close loop current	630A		630A	
Charging current	31.5A		31.5A	
Opening time	60ms		60ms	
Operation method	Manual	Motor	Manual	Motor
Control voltage	AC/DC24, 110V		AC/DC24, 110V	
Control current(at DC 110V)	5A		5A	
Weight(Non-fused LBS)	62.5kg	76kg	64kg	68kg
Manual operating cable length	1.5m (other options : 1 / 1.2 / 1.8 / 2m)			
Fuse ampere ratings	10, 16, 20, 25, 30, 40, 50, 63, 80, 100, 125, 160, 200A			

Configuration of 24kV Fused type LBS

1. Base Frame
2. Arc Chamber
3. Main Blade
4. Arcing Blade
5. Fixed Contact
6. Support Insulator
7. Support Insulator with Puffer
8. Terminal
9. Operating Rod
10. Geared Motor
11. Fuse Holder
12. Manual Operating Cable

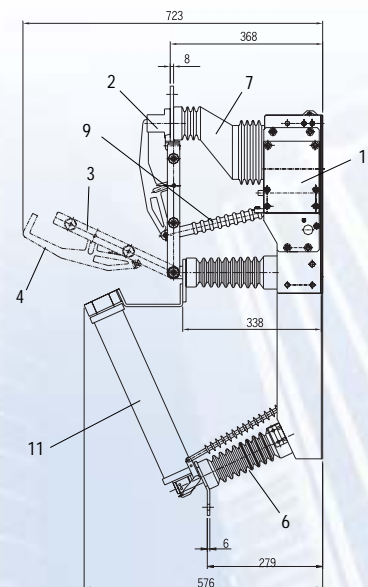
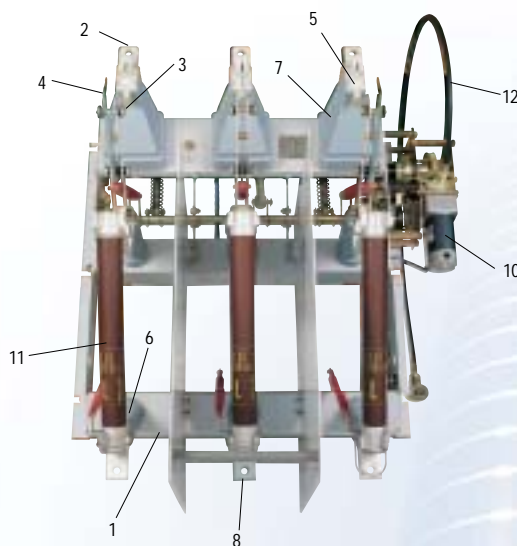

Accessories

Auxiliary relay, Motor operator, Shunt trip, Fuse trip device, Power fuse link, Fuse holder